

# WILLYS GAUGE FACEPLATE DRILL TEMPLATE

TO LOCATE AND DRILL STUD HOLES,  
CUT TEMPLATE ON DOTTED LINE AND  
USING STOCK DASH HOLES FOR  
ALIGNMENT, TAPE TO DASH.

**PRINT TEMPLATE  
AT 100% SCALE**

AFTER PRINTING, MEASURE THIS  
DISTANCE TO BE SURE SCALE OF  
PRINTED SHEET IS CORRECT

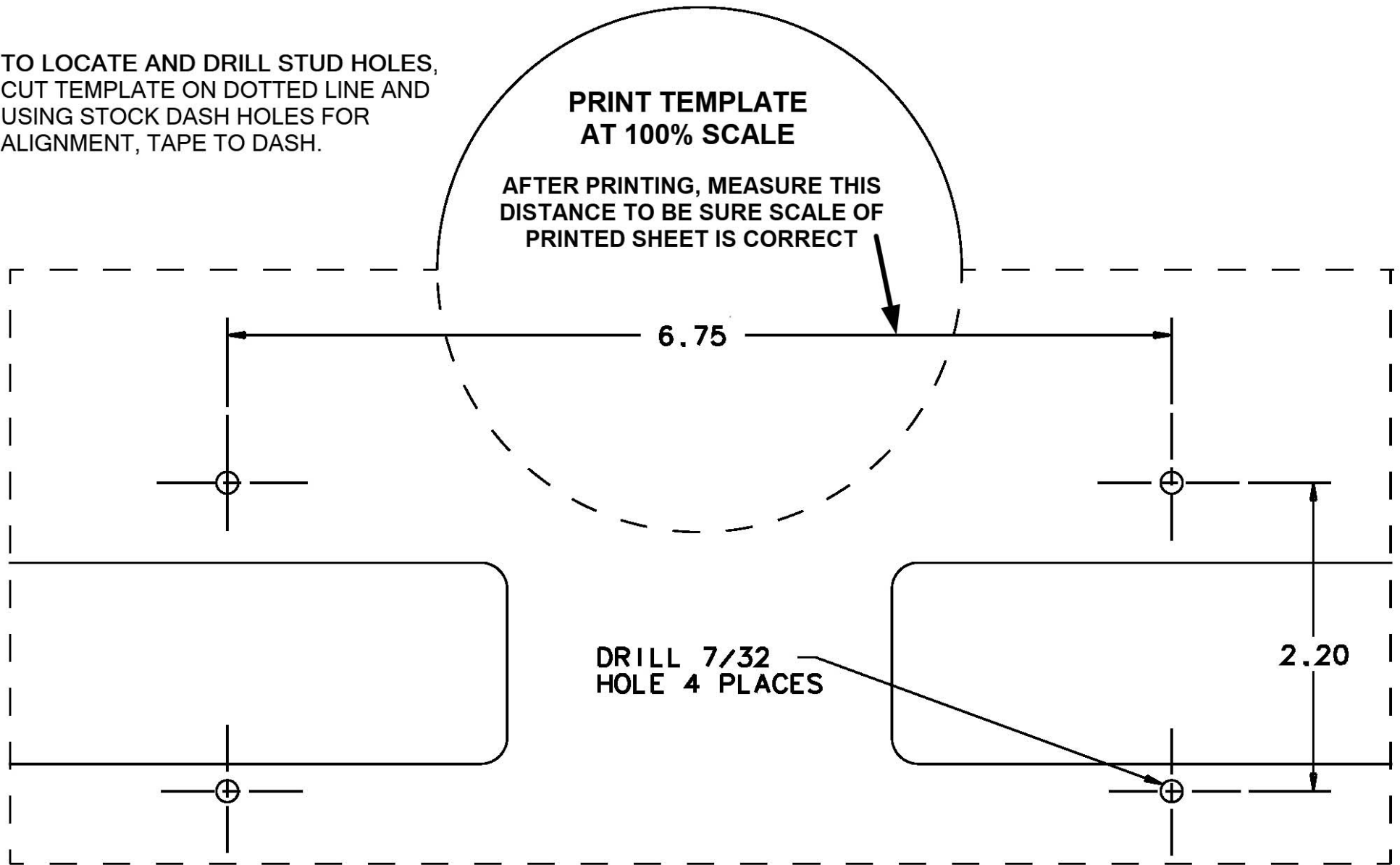

**DOUBLE CHECK YOUR SETUP BEFORE DRILLING**